





# -86°C Ultra-low Temperature Freezer

*Targeted Refrigeration • Fast Refrigeration  
Energy-saving & Environmentally Friendly  
Awarded with the Second Prize under State  
Technological Invention Award*



## DW-HL100



-  **Precise Temperature Control and Safe Storage**  
Microprocessor-based temperature controller, -40°C~86°C can be set freely with display accuracy at 0.1°C.
-  **Visual & Audio Alarm system**  
High/low temperature alarm, power failure alarm, low battery alarm, door ajar alarm, high ambient temperature alarm, communication failure alarm etc.
-  **Human-oriented**  
The rotating handle facilitates door opening;  
The two-door design including the inner door and the outer door can lock cool air inside the cabinet and ensure thermal insulation for along period.
-  **Energy-saving & Environmentally Friendly**  
Awarded with China Certificate for Energy Conservation Product, certificate numbers: CQC18702198375;  
Awarded with China Certificate for Ecolabelling Products, certificate numbers: CQC18702198376.



### High-precision Temperature Control

- Digital temperature display, simultaneously display the chamber temperature, power supply voltage, ambient temperature and other parameters etc. The running status is clearly displayed;
- The high-precision microcomputer temperature control system and platinum resistor temperature sensors enable users to set temperature inside the cabinet within a range from -40°C to -86°C.



### Refrigeration System

- The imported high-efficiency compressor and EBM fan are energy-saving and highly efficient;
- The large finned condenser with a space between fins  $\leq 2\text{mm}$ , providing effective heat dissipation;
- Standard with VIP board for high efficiency cooling performance. Door with hot gas pipe surrounding for defrost.



### Supplies for Cryopreservation

Freezer racks/boxes for cryopreservation are optional.

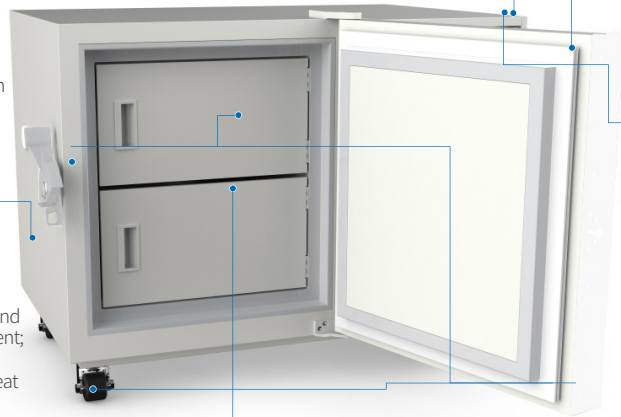

### Thermal Insulation System

- The insulated foamed outer door with seal design prevents loss of cooling capacity effectively;
- The six sides of the cabinet are made from high performance vacuum insulation material, greatly improving thermal insulation performance.



### Security System

- The perfect audible & visual alarm system: high/low temperature, sensor failure, door ajar, power failure, low battery etc;
- The turn-on delay and stopping interval protection can ensure reliable operation;
- The keyboard lock and password protection can prevent any adjustment of operation without permission.



### Human-oriented

- The door with new-type assisting door handle to be opened easily;
- Door handle with lock for safety operation.
- 304 Stainless steel interior, low temperature resistance anti-corrosion for long service life and easy cleaning;
- Universal wheels easy for movement and fixation.

## Scope of Application

Suitable for use in blood banks, hospitals, health and disease prevention systems, research institutions, colleges & universities, the electronic industry, biological engineering, laboratories in colleges & universities, military enterprises, deep-sea fishing companies, etc.

## Performance Data / Cooling Curve

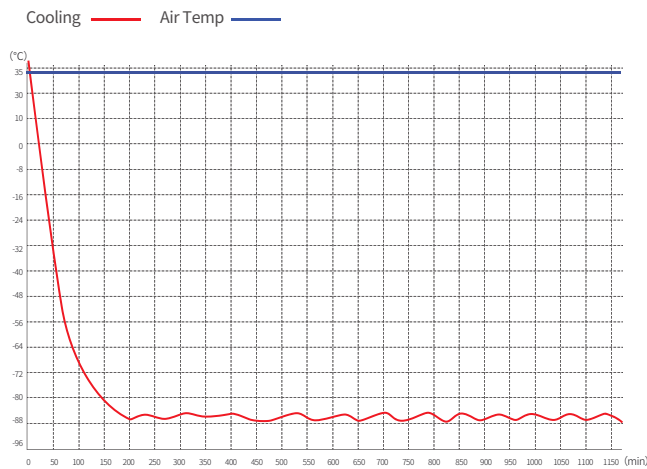

## External Dimension

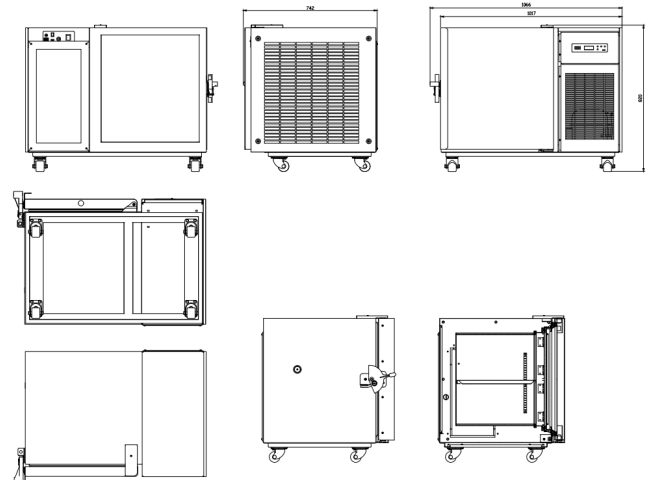

## Specification Chart

<b>-86°C Ultra-low Temperature Freezer</b>	
<b>Model</b>	DW-HL100
<b>Cabinet Type</b>	Upright
<b>Capacity(L)</b>	100
<b>Internal Size(W*D*H)mm</b>	450*439*514
<b>External Size(W*D*H)mm</b>	1074*751*820
<b>Package Size(W*D*H)mm</b>	1230*833*991
<b>NW/GW(Kgs)</b>	131/175(wood packing)
<b>Performance</b>	
<b>Temperature Range</b>	-40~-86°C
<b>Ambient Temperature</b>	16-32°C
<b>Cooling Performance</b>	-86 °C
<b>Climate Class</b>	N
<b>Controller</b>	Microprocessor
<b>Display</b>	Digital display
<b>Refrigeration</b>	
<b>Compressor</b>	1pc
<b>Cooling Method</b>	Direct cooling
<b>Defrost Mode</b>	Manual
<b>Refrigerant</b>	Mixture gas
<b>Insulation Thickness(mm)</b>	L: 90, R: 115
<b>Construction</b>	
<b>External Material</b>	Cold rolled steel sheet
<b>Inner Material</b>	Stainless steel
<b>Shelves</b>	1(stainless steel)
<b>Door Lock with Key</b>	Yes
<b>Padlock</b>	Yes
<b>Access Port</b>	1pc. Ø 25 mm
<b>Casters</b>	4
<b>Data Logging/Interval/Recording Time</b>	USB/Record every 10 minutes / 2 years
<b>Backup Battery</b>	Yes
<b>Alarm</b>	
<b>Temperature</b>	High/Low temperature,High ambient temperature, Condenser overheating
<b>Electrical</b>	Power failure , Low battery
<b>System</b>	Sensor failure, Door ajar, Built-in USB datalogger failure,Communication error
<b>Electrical</b>	
<b>Power Supply(V/HZ)</b>	110/60
<b>Accessories</b>	
<b>Standard</b>	RS485,Remote alarm contact
<b>Options</b>	Chart recorder, CO2 backup system

\*The model, parameters and performance specified in this brochure may be changed without prior notice because of product upgrading.

\*There may be differences between the product images shown in this brochure and the actual products. When you are buying any product, please check the actual product.