

MULTI SHAKER™

2D&3D motion

■ 3D-200 / Compact multi shaker

- 200X200mm platform for efficient incubator operation

■ 3D-300 / Extremely quiet operation with various movement position

- High quality DC brushless motor for gentle and powerful motion
- Installed 300X300mm platform

▶ Common facts

- BAE MECHANISM (patented, 5 step angle adjustment system) allows orbital motion and various twist movement
- Orbit of 18mm for best mixing result especially for gel and blotting
- Dual mat to accommodate each vessel
- Continuous or timed operation
- LED display shows actual speed or time

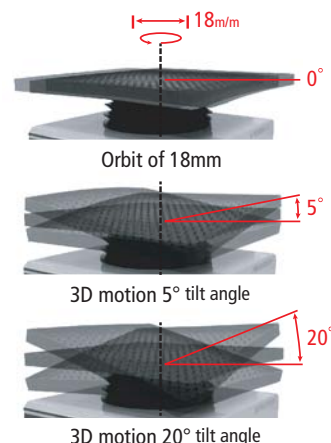

- ▶ An examples to use
- Western blotting
 - Gel staining
 - Immunoprecipitation
 - Bacteria / Yest culture



▶ 3D-200



▶ 3D-300

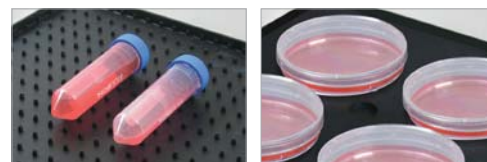

ACCESSORIES (3D-300)

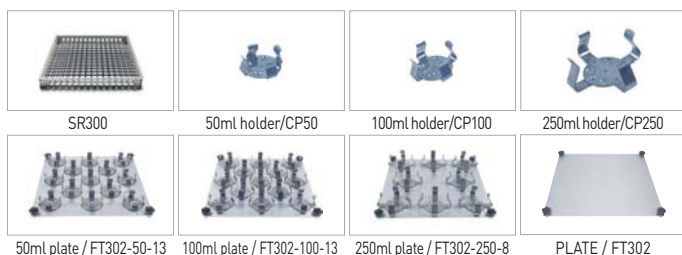

SR300 50ml holder/CP50 100ml holder/CP100 250ml holder/CP250
50ml plate / FT302-50-13 100ml plate / FT302-100-13 250ml plate / FT302-250-8 PLATE / FT302

Specification

Model	3D-200	3D-300
Speed range	5 ~ 90 rpm	30 ~ 300 rpm
Shaking Angle	orbital range-18mm 3D twist 5° 3D twist 10° 3D twist 15° 3D twist 20°	
Motor	DC Warm Gear Motor	BLDC Motor
Temp. Resist	Lower than 65°C(Hum 90%)	Lower than 55°C(Dry air)
Loadable weight	1Kg	3Kg
Timer (speed)	99hour 59min	99hour 59min
Weight	5Kg	12Kg
Dimensions (mm)	W200xD280xH147	W300xD380xH170
Platform (mm)	W200xD200	W300xD300
Wattage	35W	50W
Power	Free Voltage (AC 100-240V)	
Frequency	50/60Hz	

Accessories (3D-300)

Model Number	Description
SR300	Flexible silicon wire rack (W300xD300mm)
CP50	50ml flask holder
CP100	100ml flask holder
CP250	250ml flask holder
FT302	Universal Table for flask holder
FT302-50-13	Flask table for 50ml flask-Capacity : 13ea
FT302-100-13	Flask table for 100ml flask-Capacity : 13ea
FT302-250-8	Flask table for 250ml flask-Capacity : 8ea