

Desiccator | Aqueous Vapor



Model
MP 060 E



Model
MP 055 Z



Model
2534



Model
CRVpro 4

[Specifications & Ordering - p. 30, 34, 44, 52](#)

- Drying moist samples
- Fast pump-down of desiccator
- Oil-free options

Vacuum desiccators are used frequently in laboratories for the removal of moisture in a sample, storing moisture/oxygen-sensitive samples under a vacuum or inert atmosphere, vacuum testing, and degassing/de-foaming samples. As a result of this wide range of uses, vacuum pump selection depends on desiccator volume, vapors removed from samples and vacuum level needed to protect sample.

The volume of the desiccator needs to match the free air displacement of the pump to ensure a satisfactory pump down. Economical Wob-I® pump can be used for drying moist samples. Chemical duty diaphragm pumps are used for removing organic solvents and/or acid/bases from samples. CRVpro pumps are used for high vacuum applications where the desiccator is used for long term storage.

The common plastic and glass desiccators found in most laboratories will hold a maximum vacuum to 29 in Hg (31 mbar) for 24 hours. Some specialty manufacturers of glass and metal desiccators will rate their desiccators for long term high vacuum storage to 1×10^{-3} torr (1.3×10^{-3} mbar) and are capable of holding a vacuum at 27 in. Hg (100 mbar) for 5 years. Check with desiccator manufacturer on the vacuum rating to aid in using Welch's selector table.

Models MP 065 E, MP 055 Z These standard duty diaphragm pump models are high performance and easy-to-use solution for small benchtop desiccators. These space saving pump models have small footprints and are also portable. Ultimate vacuum pressure on MP 065 E is 100 mbar (75 torr) and MP 055 Z is <5 mbar (3.8 torr). Optional regulators and gauge assemblies are available, see page 75.

Model 2534, 2562 These Wob-I piston pumps are standard duty pumps that pack a lot of performance in small size for use with small benchtop desiccators to cabinets. Model 2534 features vacuum and pressure regulators with gauges, liquid trap at inlet and a muffler and has ultimate vacuum pressure of 27.2 in. Hg (93 mbar). Model 2562 is a two stage pump with ultimate pressure vacuum of 29.6 in. Hg (10 mbar).

Model CRVpro 4 The two-stage direct-drive rotary vane pump are suitable for long term storage applications because it is capable of reaching ultimate vacuum pressure of 29.9+ in. Hg (5×10^{-4} mbar/ 4×10^{-4} torr). This robust vacuum pump is oil-lubricated to allow it to achieve this high vacuum.

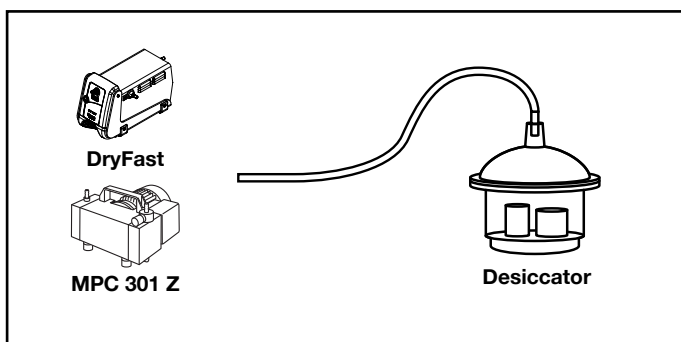
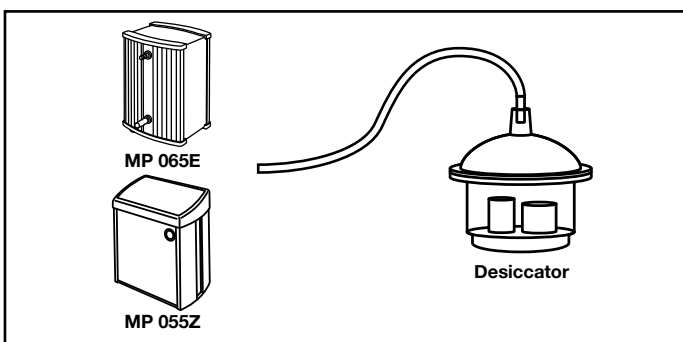
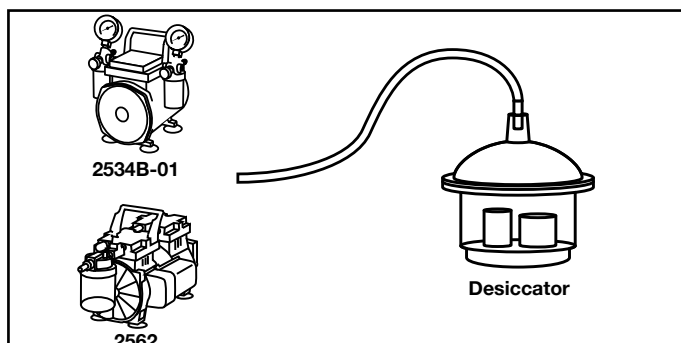

Standard Duty Dry Vacuum Pumps | WOB-L Piston



Model 2511

Models 2522 / 2534

Model 2546

Models 2567 / 2561



Specifications

Vacuum/Pressure Pumps

Model	2511	2522	2534	2546	2561
Free Air Displacement cfm (l/min.)@60Hz	0.39 (11)	0.76 (22)	1.2 (34)	1.6 (45)	2.3 (65)
m ³ /hr (l/min.)@50Hz	0.55 (9.2)	1.1 (18)	1.7 (28)	2.3 (38)	3.4 (57)
Ult. Vac. Pressure, torr(mbar)	219 (292)	100 (133)	70 (93)	60 (80)	5 (6.7)
Max Pressure PSIG (pascal)	33 (3.3 x 10 ⁵)	100 (106)	50 (5 x 10 ⁵)	100 (106)	---
Maximum Vacuum, in. Hg	21.3	26	27.2	27.6	29.8
Motor Horsepower (watts)	1/30 (25)	1/8 (93)	1/8 (93)	1/4 (190)	1/3 (250)
Tubing Needed, I.D. in. (mm)	3/16 (5)	3/16 (5)	3/16 (5)	3/16 (5)	1/4 (7)
Intake/Exhaust Thread NPT	3/16 in. Hose	1/4	1/4	1/4	1/4
Weight lbs.(kg)	5 (2.3)	11.7 (5.3)	11.7 (5.3)	13.8 (6.3)	16.5 (7.5)
Overall Dimensions L x W x H in. (cm)	7.6x4.5x7.5 (19x11x19)	8.1x8.8x10 (21x22x25)	8.1x8.8x10 (21x22x25)	10x7.5x9 (25x19x8)	17.3x6.5x10.5 (44x17x27)
Ship Weight, lbs. (kg)	6 (2.7)	17 (7.7)	17 (7.7)	17 (7.7)	24 (10.9)
Shipping Carton Dimensions L x W x H in. (cm)	11x7x8.3 (28x18x21)	15.3x12.3x12.7 (39x31x32)	15.3x12.3x12.7 (39x31x32)	15.3x12.3x12.7 (39x31x32)	21x12x15 (53x30x38)

Ordering Information

Wired for 115V, 60Hz, 1 Ph with N. American 115V Plug	2511B-01 ³	2522B-01 ⁴	2534B-01 ⁴	2546B-01 ⁴	2561B-50
Wired for 230V, 60Hz, 1 Ph with N. American 230V Plug	---	---	2534C-01 ^{4,7}	2546C-01 ^{4,7}	---
Wired for 230V, 50Hz, 1 Ph2. with Cont. Euro.(Schuko) Plug	2511C-02 ³	2522C-02 ^{4,6}	2534C-02 ^{4,6,7}	2546C-02 ^{4,6,7}	2561C-50 ^{6,7,8}
Wired for 100V, 50/60Hz, 1 Ph with a plug	2511C-05 ^{3,5}	2522C-05 ^{4,5}	---	---	---

Applications

	page
1. Vacuum Filtration	18
2. Vacuum Oven	22
3. Desiccator	20
4. Aspiration / Automation	12
5. Cell Culture	12
6. Glove Box	26

Vacuum/Pressure Standard Duty Dry Vacuum Pumps

- Ultimate to <5 torr (6.7 mbar)
- Lightweight, compact pump
- Inlet liquid trap with vacuum regulator

Oil-free operation for reduced maintenance. These WOB-L piston pumps have a high water vapor tolerance. Pumps come with inlet liquid trap, mounted vacuum gauge and vacuum regulator (except 2511 and 2562).

Note: Standard Duty Dry Pumps are not recommended for pumping organic, acidic or basic vapors.



Model 2585B-50

Standard Duty Dry Vacuum Pumps | WOB-L Piston



**Model
2562B-01**



**Models
2585 / 2581**



**Model
2511B-75**



**Model
2515B-75**

Standard Duty Vacuum Pumps				Aspiration/Filtration Systems	
2562	2567	2581	2585	2511	2515
2.3 (65)	3.5 (100)	3.5 (100)	7.1 (201)	0.39 (11)	1.2 (34)
3.4 (57)	4.9 (83)	4.9 (83)	10 (168)	0.55 (9.2)	1.7 (28)
7.5 (10)	60 (80)	5 (6.7)	60 (80)	219 (292)	70 (93)
---	---	---	---	33 (3.3 x 105)	---
29.6	27.6	29.8	27.6	21.3	27.2
1/3 (250)	1/3 (250)	1/3 (250)	1/3 (250)	1/30 (25)	1/8 (93)
3/8 (10)	1/4 (7)	1/4 (7)	1/4 (7)	3/16 (5)	3/16 (5)
1/4	1/4	3/8	3/8	3/16 in. Hose	1/4
16.5 (7.5)	16.5 (7.5)	24.5 (11.1)	24.5 (11.1)	5.7 (2.6)	13.2 (6.0)
17.0x7.5x12 (43x19x31)	15.0x10x10 (38x25x25)	17x7.5x12 (43x42x19)	17x7.5x12 (43x42x19)	11.0x8.3x10.0 (28x21x25)	14.8x8.3x10.0 (37.5x21x25.5)
24 (10.9)	24 (10.9)	32 (14.5)	32 (14.5)	11.0 (5)	14.8 (6.7)
21.5x12.5x16 (55x32x31)	21x12x15 (53x30x38)	21x12x15 (53x30x38)	21x12x15 (53x30x38)	15.3x12.3x12.7 (39x31x32)	21x12x15 (53x30x38)
2562B-01	2567B-50	2581B-50	2585B-50	2511B-75	2515B-75
---	---	---	---	---	---
---	2567C-50 ^{6, 7, 8}	2581C-50 ^{6, 7, 8}	2585C-50 ^{6, 7, 8}	2511C-75 ^{6, 7, 8}	2515C-75 ^{6, 7}
---	---	---	---	2511C-76 ⁵	2515C-76

Notes:

- All models are recommended for pumping vapors of aqueous solutions including buffers, but not for acidic, basic or organic vapors or gases.
- Units supplied with CE marking.
- Model 2511 can deliver 33 PSIG (3.3 x 10⁵ pascal).
- Models 2522, 2534 and 2546 come with vacuum (and pressure) regulator, vacuum (and pressure) gauge, silencer and water trap. Models 2522 and 2546 can deliver 100 PSIG (10⁶ pascal). Model 2534 can deliver 50 PSIG (5 x 10⁵ pascal).
- Comes with PSE mark.
- Included is UK and Schuko cord sets.
- Motor can operate at 230V, 50/60Hz, 1Ph.
- For 230V in US, order cord 61-8707.

Aspiration / Filtration Systems

Systems collect waste into 1.2 Liter autoclavable reservoir. Both models enable vacuum measurement and regulation. Reservoirs are protected from overflow by float valve; inlet line hydrophobic filter further protects pump. Includes 6 ft. tubing and 2 filters. See p. 10 for more information. For accessories, like pipettor system and foot switches, see page 78.



**Model
2511B-75**



**Model
2515B-75**

For a Complete System

Component	page
• Traps	69
• Inlet / Exhaust Accessories	69, 71
• Hose	67
• Gauges	76
• Service Kits	80 - 81
• Replacement Jars	79

Standard Duty Dry Piston Pump Kits



- Rebuild kit includes connecting rod, o-rings, cylinder sleeve, piston cup, rubber suction feet and retainer screws

Pump Model	KIT No.	Description
2522	2522K-03	Complete Rebuild Kit
2534B-01	2534K-03	Complete Rebuild Kit
2534C-01, -02	2546K-03	Complete Rebuild Kit
2546	2546K-03	Complete Rebuild Kit
All Models WOB-L ⁺ Dry Pump	2500K-04	Service Kit for Feet

DuoSeal[®] Vacuum Pumps



- Minor repair kit includes shaft seal, intake screen, gaskets, springs, valves and spring holders
- Major repair kit includes everything in minor repair kit plus large and small metal vanes

Pump Model	KIT No.	Description
1400	1400K-03	Minor repair kit, 1400
	1400K-04	Major repair kit, 1400
1402, 1405	1402K-05	Minor repair kit, 1402 & 1405
	1402K-06	Major repair kit, 1402 & 1405
1376	1376K-05	Minor repair kit, 1376
	1376K-06	Major repair kit, 1376
1397, 1374	1397K-07	Minor repair kit, 1397 & 1374
	1397K-08	Major repair kit, 1397 & 1374
1399	1399K-03	Minor repair kit, 1399
	1399K-04	Major repair kit, 1399
1373	1373K-05	Minor repair kit, 1373
	1373K-06	Major repair kit, 1373

Chemstar[®] Vacuum Pumps



- Minor repair kit includes shaft seal, intake screen, gaskets, springs, valves and spring holders
- Major repair kit includes everything in minor repair kit plus large and small metal vanes

Pump Model	KIT No.	Description
1400N	1400K-09	Minor repair kit, ChemSTAR 1400N
	1400K-10	Major repair kit, ChemSTAR 1400N
1402N	1402K-09	Minor repair kit, ChemSTAR 1402N
	1402K-10	Major repair kit, ChemSTAR 1402N
1376N	1376K-09	Minor repair kit, ChemSTAR 1376N
	1376K-10	Major repair kit, ChemSTAR 1376N

CRVpro Vacuum Pumps



- Minor repair kit includes shaft seal, intake screen, gaskets, springs, valves and spring holders

Pump Model	KIT No.	Description
CRVpro 4	S3077-99	Repair Service Kit
CRVpro 6	S3078-99	Repair Service Kit
CRVpro 8	S3079-99	Repair Service Kit
CRVpro 16	S3193-99	Repair Service Kit
CRVpro 24	S3197-99	Repair Service Kit
CRVpro 30	S3198-99	Repair Service Kit
CRVpro 4/6/8	S3080-99	Seal Kit
CRVpro 4/6/8	S3091-99	Lip Seal Kit
CRVpro 16/24/30	S3192-99	Seal Kit
CRVpro 16/24/30	S3199-99	Lip Seal Kit