

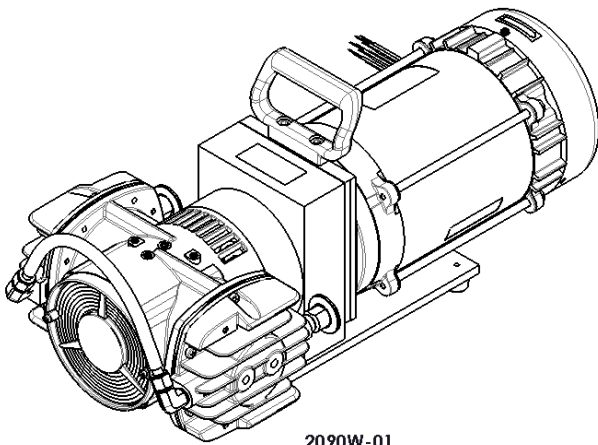

WELCH

by Gardner Denver

OWNER'S MANUAL FOR DRY VACUUM PUMPS MODELS 2090W-01 and 2085W-01



2090W-01

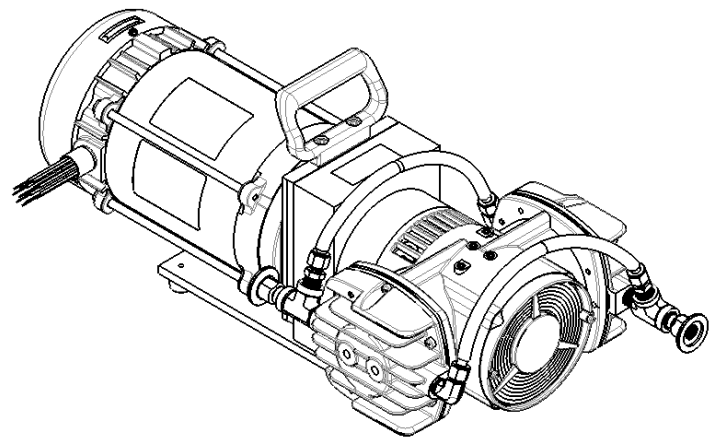

2085W-01



WARNING

**Be sure to properly identify intake and discharge
before using pump. See Section 2.5.**

**Part No. 642978
Printed in the U.S.A.**

Section 6: SPECIFICATIONS

Welch Model	2090	2085
Free Air Displacement CFM (L/min)@60Hz	4.5 (127)	6.9 (176)
Ult. Press., Torr (mbar)	25 (33)	100 (133)
Max Vacuum, in. Hg	29	26
Number of Vacuum Stages	2	1
Motor Horsepower	1/2	1/2
Vacuum Restart	yes	yes
Minimum Tubing Needed, I.D. in.	7/16	7/16
Weight, lbs. (kg)	52 (23.6)	52 (23.6)
Catalog Number	2090W-01	2085W-01
Motor Voltage	115V / 208-230V / 1PH / 60HZ	
Motor Amps	9.8 / 4.9-4.9	
Motor Hazardous Classification	CLASS 1 DIV 1 GROUP C,D CLASS 2 DIV 1 GROUP E,F,G	

Exploded View for 2090W-01

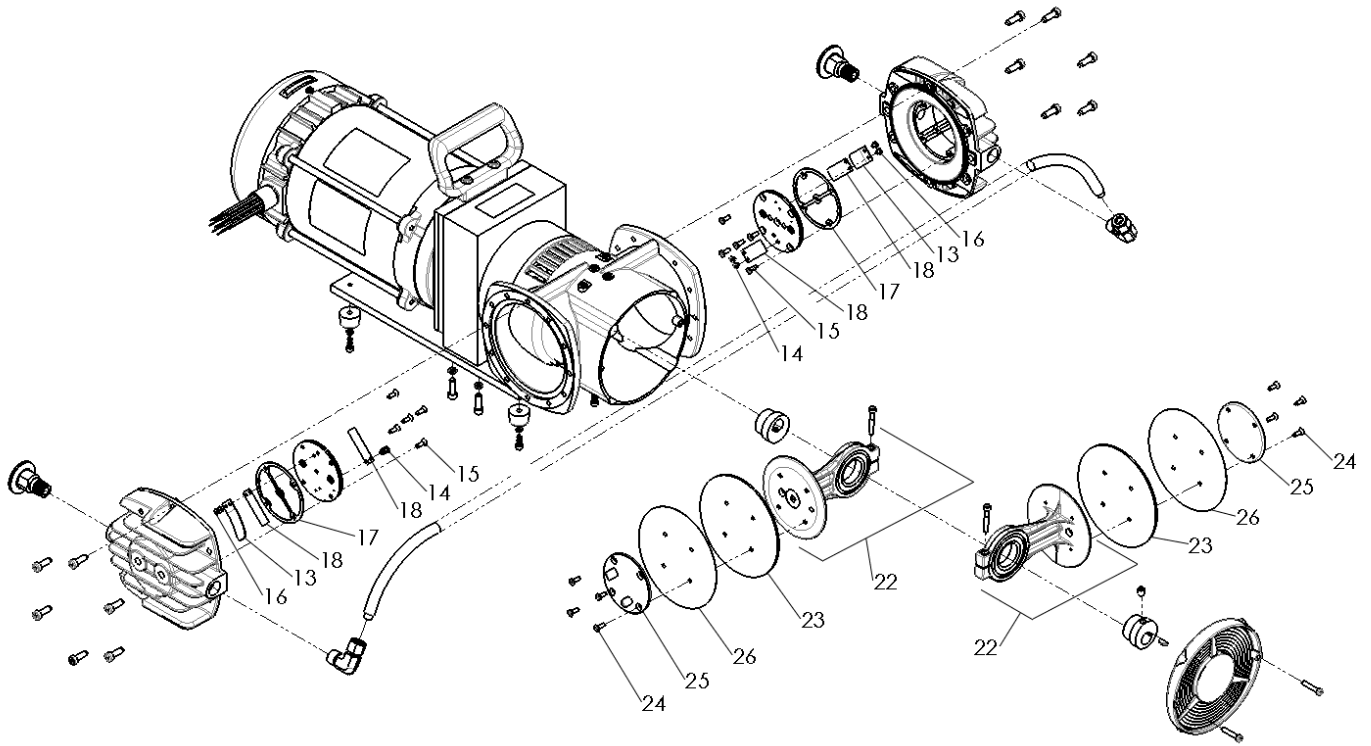

Parts List for 2090W-01

Item No.	Part No.	Description	Diaphragm Service Kit 2090K-01	Valve Plate Service Kit 2090K-02
13	See Note 1	Valve Keeper	-	2
14	See Note 1	Screw-Valve Flapper-Intake	-	4
15	See Note 1	Screw-Valve Plate	-	10
16	See Note 1	Screw-Valve Flapper-Exhaust	-	4
17	See Note 1	Valve Plate Gasket	-	2
18	See Note 1	Valve Flapper-Intake & Exhaust	-	4
22	-	Connecting Rod	-	-
23	See Note 1	Diaphragm	2	-
24	See Note 1	Screw-Hold Down Plate	8	-
25	See Note 1	Hold Down Plate	2	-
26	See Note 1	PTFE Liner	2	-

Note 1: These parts are not available separately, but are supplied within kits.