

# Rugged Belt Drive Vacuum Pumps | DUOSEAL®



**Model  
1400**

**Models  
1405 / 1402**

**Model  
1376**

**Models  
1397 / 1374**

## Specifications

## Two-Stage Vacuum Pumps

Model	1400	1405	1402	1376	1397	1374
Free Air Displacement						
cfm	0.9	3.2	5.6	10.6	17.7	23
l/min.	25	90	160	300	500	650
Ult. Vac. Pressure, torr (mbar) <sup>1,2</sup>	1 x 10 <sup>-4</sup> (0.00013)	1 x 10 <sup>-4</sup> (0.00013)	1 x 10 <sup>-4</sup> (0.00013)	1 x 10 <sup>-4</sup> (0.00013)	1 x 10 <sup>-4</sup> (0.00013)	1 x 10 <sup>-4</sup> (0.00013)
Gas Ballast	Yes	Yes	Yes	Yes	Yes	Yes
Discharge Pressure (PSIG)	---	---	---	---	---	---
Pump RPM	580	525	525	525	400	510
Motor Horsepower (watts)	1/3 (250)	1/2 (370)	1/2 (370)	1 (750)	1 (750)	1-1/2 (1120)
Oil Capacity, qt.(liters)	0.62 (0.59)	2.25 (2.1)	2.25 (2.1)	2.5 (2.4)	1.25 (1.2)	1.25 (1.2)
Tubing Needed, I.D. in.	7/16 (11)	7/16 (11)	13/16 (21)	13/16 (21)	1-5/8 (41)	1-5/8 (41)
Intake, Nipple Thread	3/4-20	1-20	1-20	1-20	1.75-20	1.75-20
Exhaust, Thread Type	3/4-20	1-20	1-20	1-20	1.75-20	1.75-20
Weight, lbs. (kg)	58 (26)	112 (51)	112 (51)	156 (71)	205 (93)	220 (100)
Overall Dimensions LxWxH in.(cm)	17.8x9x12.6 (45.1x32.1x31.8)	20x12x15 (51x30.5x60)	20x12x15 (51x30.5x60)	20x14.1x15.4 (51x35.9x39)	26x13.7x18.8 (66x34.8x47.6)	26x13.7x18.8 (66x34.8x47.6)
Ship Weight, lbs. (kg)	70 (31.8)	132 (60)	132 (60)	180 (81.8)	213 (96.8)	215 (97.7)
Shipping Carton Dimensions LxWxH in.(cm)	20.5x13.8x14.5 (52.1x35.1x36.8)	22.5x15.5x19.5 (57.2x39.4x49.5)	22.5x15.5x19.5 (57.2x39.4x49.5)	22x18x19 (55.9x45.7x48.3)	27.3x18x22 (69.3x45.7x55.9)	27.3x18x22 (69.3x45.7x55.9)

## Ordering Information<sup>3,4</sup>

Wired for 115V, 60Hz, 1 Ph with N. American 115V Plug	1400B-01	1405B-01	1402B-01	1376B-01	1397B-01	1374B-01 <sup>5</sup>
Wired for 230V, 60Hz, 1 Ph with N. American 230V Plug	1400C-01	1405C-01	1402C-01	---	---	---
Wired for 220V, 50Hz, 1 Ph w/Cont. Euro. (Schuko) Plug	1400C-02	1405C-02	1402C-02	1376C-03	1397C-03	---
Explosion Proof Motor, 115V, 60 Hz	1400W-01	1405W-01	1402W-01	---	---	---
3-Phase Motor 230V, 460V, 60Hz	---	---	1402M-01	1376M-01	1397M-01	1374M-01
Wired for 115V, 60Hz, 1 Ph with N. American 115V Plug, CSA	1400B-80	1405B-80	1402B-80	---	1397B-80	---

## Applications

	page
1. Freeze Drying	17
2. Glove Box	26
3. Vacuum Manifold / Schlenk Line	11
4. Vacuum Ovens	23
5. Refrigeration Servicing	24 - 25

### DuoSEAL Pumps

Rugged oil-seal pumps for a wide variety of vacuum needs, including Schlenk drying lines, freeze drying, degassing, concentrations, distillations, and more. Pulley drive enables low pump rpm operation - reduces friction, oil temperature, and oil degradation. Large oil reservoir minimizes contamination effects and extends maintenance intervals. Use of a cold trap is recommended to protect the pump and enhance vacuum levels.

### Refrigeration Servicing Pumps

Special Welch DuoSEAL pumps are fitted with components designed to withstand refrigerant contact. Models 1402B-46 and 1397B-46 include integrated handles.



### Notes:

- Two-stage pumps should not be operated continuously at pressures above 10 torr. Ultimate pressure measured with a trapped McCleod gauge.
- One-stage pumps should not be operated continuously at pressures above 50 torr.

# Rugged Belt Drive Vacuum Pumps | DUOSEAL<sup>®</sup>, CAPTURE



**Model  
1399N**



**Model  
1402B-46**



**Model  
1376B-46**



**Model  
CRR-1A**

One-Stage Vacuum Pumps			Refrigeration Servicing Pumps			CAPTURE Refrigerant Recovery
w/o plate	w/bell jar plate	w/o plate				
1399	1399N	1380	1402B-46	1376B-46	1397B-46	CRR-1A
1.2	1.2	5.6	5.6	10.6	17.7	10.6
35	35	160	160	300	500	300
1.5 x 10 <sup>-2</sup> (0.019)	1.5 x 10 <sup>-2</sup> (0.019)	1.5 x 10 <sup>-2</sup> (0.019)	1 x 10 <sup>-4</sup> (0.00013)	1 x 10 <sup>-4</sup> (0.00013)	1 x 10 <sup>-4</sup> (0.00013)	3x10 <sup>-2</sup> (0.04)
No	No	Yes	Yes	Yes	Yes	---
---	---	---	---	---	---	30
750	750	535	525	525	400	525
1/3 (250)	1/3 (250)	1/2 (370)	1/2 (370)	1 (750)	1 (750)	1 (750)
0.5 (0.47)	0.5 (0.47)	3.7(3.5)	2.25 (2.1)	2.5 (2.4)	1.25 (1.2)	2.5 (2.4)
7/16 (11)	7/16 (11)	13/16 (21)	3/4" ID Flare	3/4" ID Flare	Note 7	----
3/4-20	3/4-20	1-20	1-20	1-20	1.75-20	1 NPT
3/4-20	3/4-20	1-20	1-20	1-20	1.75-20	1 NPT
51 (23)	63 (28.6)	91(41)	112 (51)	156 (71)	205 (93)	122 (55.4)
17x9x10 (43.x23x25)	17x9x10 (43.x23x25.)	20x12x15 (51x31X38)	20x12x15 (51x30.5x60)	20x14.1x15.4 (51x35.9x39)	26x13.7x18.8 (66x34.8x47.6)	19.25x12.3x11.1 (48.9x31.3x28.1)
62 (28.2)	74 (33.6)	116 (53)	132 (60)	180 (81.8)	213 (96.8)	136 (61.8)
21x14x15 (52x35x37)	21x14x15 (52x35x37)	23x15x18 (56x38x47)	23x16x20 (57x39x50)	22x18x19 (56x46x48)	28x18x22 (69x46x56)	22x15x18 (56x38x46)
1399B-01	1399N-01	1380B-01	1402B-46	1376B-46	1397B-46	CRR-1A
---	---	---	---	---	---	----
1399C-02	---	---	1402C-46	1376C-46	1397C-46	CRR-1B
---	---	---	---	---	---	----
---	---	---	---	---	---	----
---	1399B-80	---	---	---	---	---

- All 115V and 230V single phase motors include thermal overload protection.
- Models 1400C-02, 1405C-02 and 1402C-02 provided with CE marking.
- Conduit wiring installation required. No cord, plug or switch provided.
- CSA approved models are 1400B-80, 1405B-80 and 1402B-80.
- 1-1/2" NPT Female

**DuoSeal™ Vacuum Pump Oil**  
Tested to high vacuum levels, this oil meets rigid requirements for vapor pressure, stability and viscosity.

Size	CAT. No.
Quart	1407K-11
Gallon	1407K-15
5 Gallon	1407K-20



**Exhaust Filter**  
A replaceable filter element captures oil mist from the exhaust port of the pump and reduces pump noise.



Pump	CAT. No.
1399, 1400	1417
1376, 1402, 1405	1417P-10
1397, 1374	1417P-20

## For a Complete System

Component	page
• Traps	69
• Inlet / Exhaust Accessories	69 - 71
• Fittings / Hose	66 - 68
• Gauges	76 - 77
• Regulators / Controllers	75 - 76
• Service Kits	81
• Oil	72 - 73

Apply deep vacuum to your system in the toughest conditions. CHEMSTAR® pumps are built to withstand corrosive chemical vapor environments - durable performance over the long haul. CHEMSTAR® is designed to minimize the effects of harmful chemicals:

## Rugged Rotary Vane Design

Built to the renowned performance standards of Welch DUOSEAL® pumps, CHEMSTAR® utilizes vapor contact components that are tough and chemical resistant. The belt-drive mechanism gears the pump down, enabling slow pump operation to reduce friction and keep operating temperatures low.

## Lubrication System

The oil capacity is large for excellent dilution of contaminants. Oil is fed to the pump from the top of the reservoir, allowing sludge to settle without compromising lubrication. The recommended lubricant ("Gold Oil") is a synthetic oil designed to reduce chemically active sites. Use the nitrogen purge to drive elimination of corrosive gases.

## Key Accessories

Welch also provides the system add-ons that further protect your pump and your environment. Select the equipment that augments your vacuum system needs - traps, oil mist eliminators, and system components.

## The Five Defining Features Needed For Pumping Corrosive Gases

### 1. High Contamination Tolerance

- Contaminants diluted
- Fewer moving parts
- Top oil feed for cleaner oil

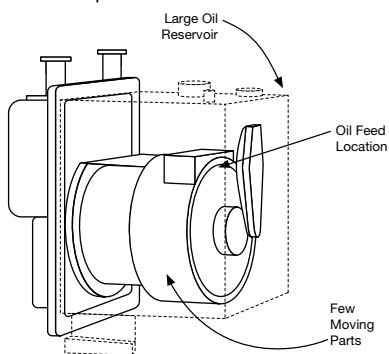

### 2. Vital Parts Corrosion Resistant

- Fluoroelastomer seals and gaskets
- PTFE
- Stainless Steel
- Nickel Plated or Anodized
- Chemical Resistant Grade of Cast Iron

### 3. Reduced Frictional Wear

- Less than 580 RPM vs. typical 1750 RPM direct drive

### 4. Nitrogen Purge Standard

- Degasses and cools oil

### 5. Easy Attachment of Accessories

- Complete accessory package for corrosive gases

- HCl
- H<sub>2</sub>SO<sub>4</sub>
- HOAc
- Br<sub>2</sub>
- H<sub>2</sub>S
- CH<sub>2</sub>O
- O<sub>3</sub>
- HBr
- SO<sub>x</sub>
- F<sub>3</sub>CCO<sub>2</sub>H
- Cl<sub>2</sub>
- HNO<sub>3</sub>
- SF<sub>6</sub>, CF<sub>4</sub> fragments and other gases



Model 1402N

Specifications & Ordering - See Below

Specifications			
Model	1400N	1402N	1376N
Free Air Displacement			
cfm (l/min.)@60 Hz	0.9	5.6	10.6
m <sup>3</sup> /hr (l/min.)@50 Hz	25	160	300
Ultimate Pressure, torr(mbar) <sup>1</sup>	1 x 10 <sup>-4</sup> (0.00013)	1 x 10 <sup>-4</sup> (0.00013)	1 x 10 <sup>-4</sup> (0.00013)
Gas Ballast	Yes	Yes	Yes
Pump RPM	580	525	525
Motor Horsepower (watts)	1/3 (250)	1/2 (370)	1 (750)
Oil Capacity, qt.(liters)	0.62 (0.59)	2.25 (2.1)	2.5 (2.37)
Tubing Needed, I.D. in.	7/16 (11)	13/16 (21)	13/16 (21)
ISO Exhaust & Intake Flange <sup>5</sup>	NW 16	NW 25	NW 25
Overall Dimensions LxWxH in.(cm)	17.8x9x12.6 (45.2x22.9x32)	19.3x14.1x15.4 (49x35.3x39.1)	19.3x12.3x15.6 (49x31.2x39.6)
Weight, lbs.(kg)	58(26)	112(51)	156(71)
Ship Weight, lbs.(kg)	71(32.3)	133(60.5)	181(82.3)
Shipping Carton Dimensions LxWxH in.(cm)	20.5x13.8x14.5 (52.1x35.1x36.8)	22.5x15.5x19.5 (57.2x39.4x49.5)	22x18x19 (59.5x45x48)
Ordering Information <sup>2, 4</sup>			
Wired for 115V, 60Hz, 1 Ph w/N. American 115V Plug	1400N-01	1402N-01	1376N-01
Explosion Proof Motor 115V, 60Hz, 1 Ph	1400N-90 <sup>3</sup>	1402N-90 <sup>3</sup>	---
Wired for 230V, 60Hz, 1 Ph w/ N. American Plug	---	1402N-60	1376N-60
Wired for 220V, 50Hz, 1 Ph w/ Cont. Euro. (Schuko) Plug	1400N-50 <sup>6</sup>	1402N-50 <sup>6</sup>	1376N-49
Wired for 100V, 50/60Hz, 1 Ph for Japan	1400N-53	1402N-53	1376N-53

#### Notes:

1. CHEMSTAR pump should not be operated continuously at pressures above 10 torr. Ultimate pressure measured with a trapped McCleod gauge.
2. All single phase motors have overload protection.
3. Conduit wiring installation required. No cord, plug or switch provided.
4. Hinged clamp, centering ring assembly and hose adapter are included with all CHEMSTAR Pumps.
5. Standard filter option possible if the exhaust flange is removed, but not chemically resistant.
6. Units supplied with CE marking.



Model  
CRR-1A

- Continuous discharge pressure to 30 psig(2.1 Bar)
- Pump shell rated to 100 psig (2.1 Bar)
- Minimal loss of pumping efficiency below 29.9” Hg (1000 microns/1.3 mbar)
- High flow rate of 10.6 cfm(300 lpm)
- Durable cast iron construction
- Proven dependability

The CAPTURE pump has been specifically designed for refrigerant recovery and recycling systems requiring chiller evacuation to 29.9 in. Hg(1000 micron/1.3 mbar) while subsequent boosting of refrigerant vapor to a holding tank to 30 psig(2.1 Bar). CAPTURE pumps are the heart of transportable recovery systems used for recovering low and medium pressure refrigerants, such as R-123 and R-11.

Recovery with the CAPTURE pump can be configured in a recovery system to employ the liquid-vapor method. The first step is the recovery cylinder is evacuated with the CAPTURE pump and that pulls the refrigerant from chiller into the cylinder. Once

the liquid refrigerant is recovered, valves are switched on the recovery system, so that the remaining vapor in chiller is evacuated by the pump and boosted into chiller. The CAPTURE pump then reaches vacuum pressure levels in chiller that are required by the Clean Air Act.

Pump oil separation from refrigerant vapor and return to pump is accomplished by attaching a standard float actuated oil return found in refrigerators. The oil separator is a proven technology that minimizes pump oil loss even for very large refrigerant systems. DUOSEAL pump oil, CAT no. 1407K-11, is recommended lubricant to operate the CAPTURE pump.

## Specifications

### Model

CRR-1

Free Air Displacement

cfm(lpm)

10.6 (300)

Ult. Vac. Pressure, torr (mbar)

3x10<sup>-2</sup> (0.04)

Max Vacuum, in Hg

29.9+

Discharge Pressure, psig(bar)

30 (2.1)

Pump RPM

525

Motor Horsepower (watts)

1(750)

Oil Capacity, qt. (liters)

2.5(2.4)

Intake thread, NPT in.

1

Exhaust thread, NPT in.

1

Weight, lbs (kg)

112(55.5)

Overall dimensions LxWxH in.(cm)

19.3x12.3x11.1 (49x31.2x28.2)

Ship Weight, lbs. (kg)

170((77.3)

Shipping Carton Dimensions LxWxH in. (cm)

20x14.1x15.4 (55.9x45.7x48.3)

## Ordering Information

Wired for 115V, 60Hz, 1 Ph with N. American 115V plug

CRR-1A

Wired for 230V, 50Hz, 1 Ph w/Cont. Euro. (Schuko) plug

CRR-1B

Mounted pump on base with guard, but without motor

CRR-1C